

**wa** | **Knoll**

**wa**

visual silence.

simplicity without technical compromise.

the simplicity of complexity.

**wa** | **Knoll**





## click

the underside of every worksurface is fitted with a perimeter slot.  
a simple clip allows you to connect anywhere along the entire table edge.  
worksurfaces and accessories can dock at any point in the slot.

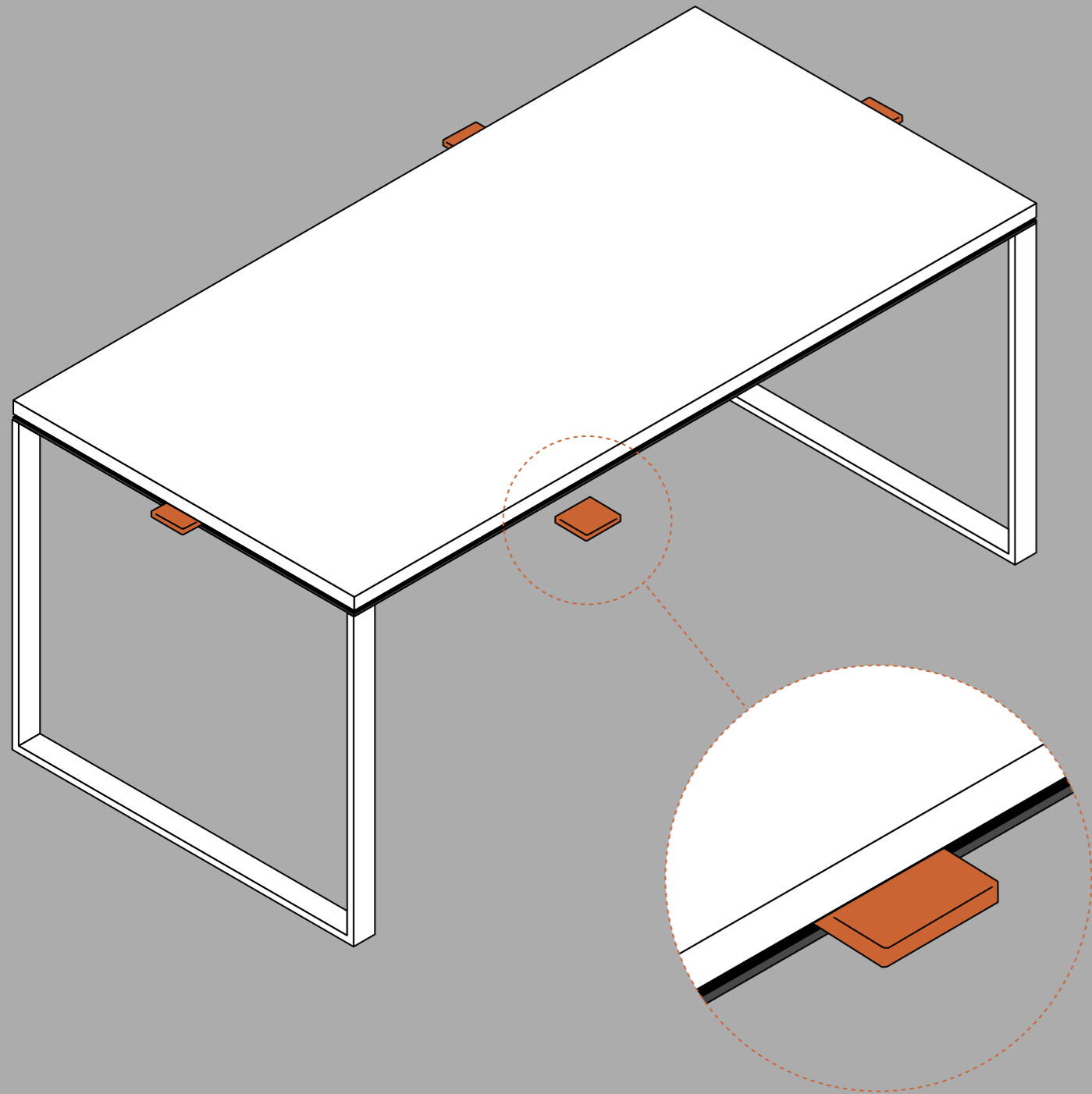

## connect

almost any configuration is possible.  
there are no modular restrictions.

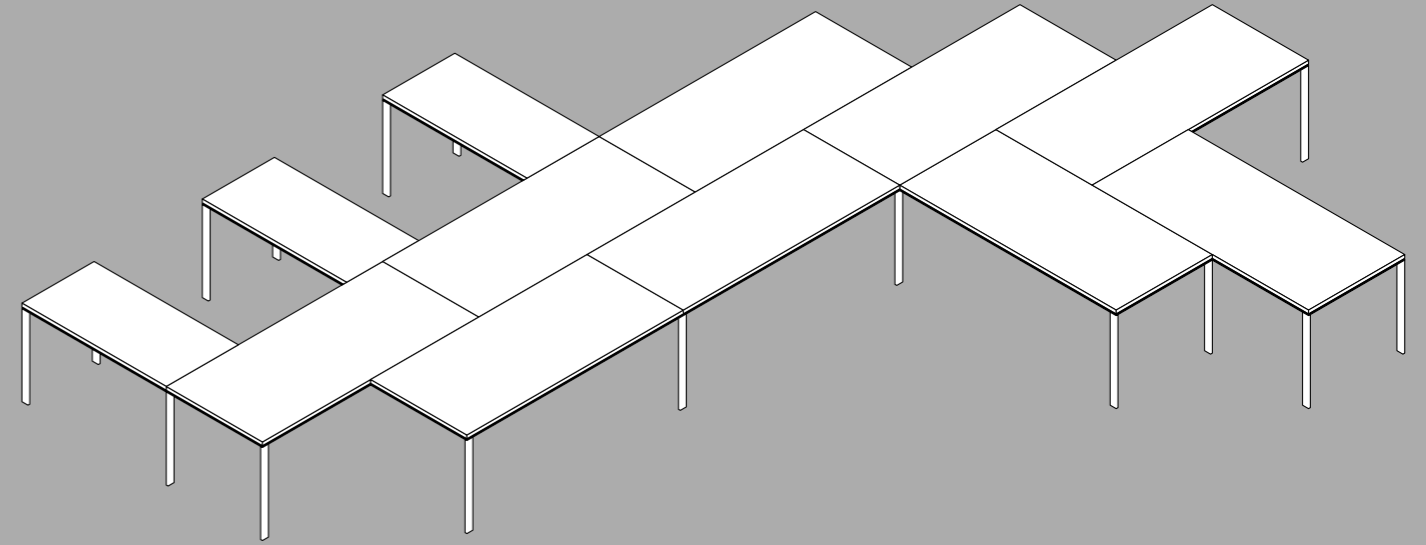

## in footprint, on axis

legs can be fitted to the corners of desks.  
or shared between two worksurfaces.  
every leg is height adjustable, from 68.5 to 76 cm.

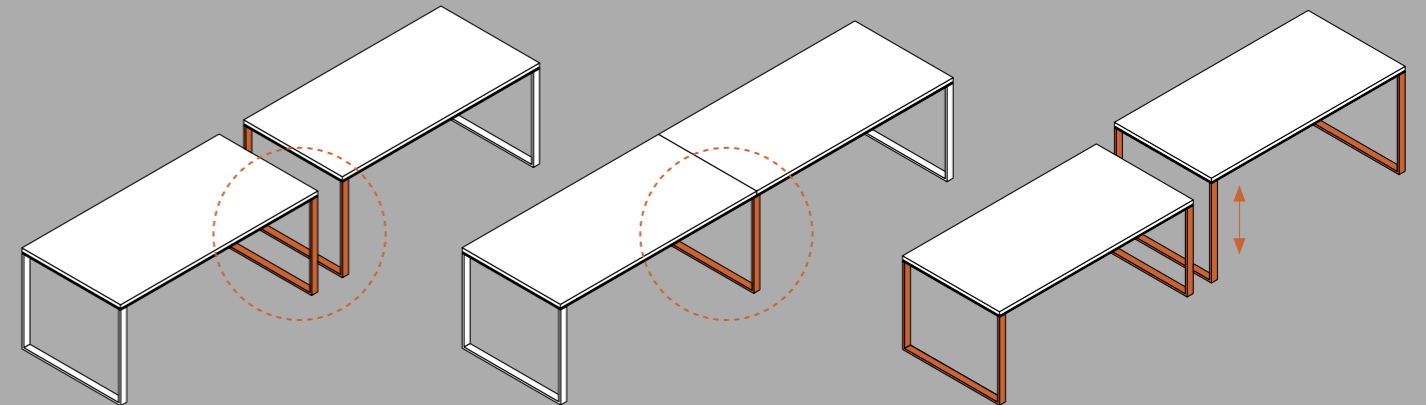

## support

single legs, 'U' legs, panel legs.

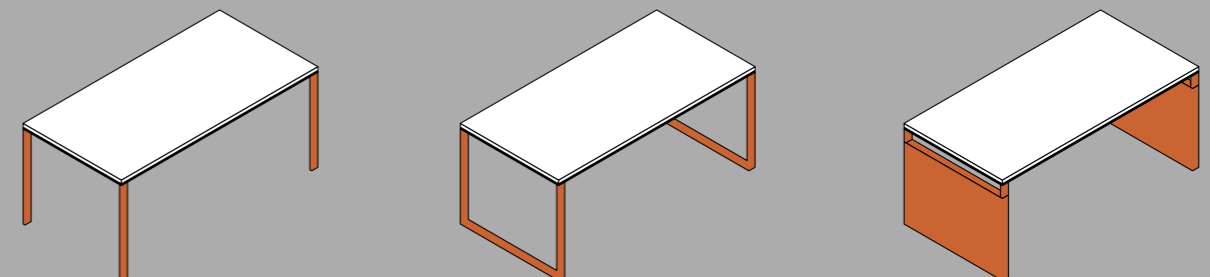



## the soft concept

a response to computer related repetitive strain injuries.  
a soft interface between the body and workplace.  
soft parts offer choice; the key ergonomic requirement.  
soft parts can expand the work place dimensions,  
define and personalise territories.  
click connect anywhere on the perimeter.

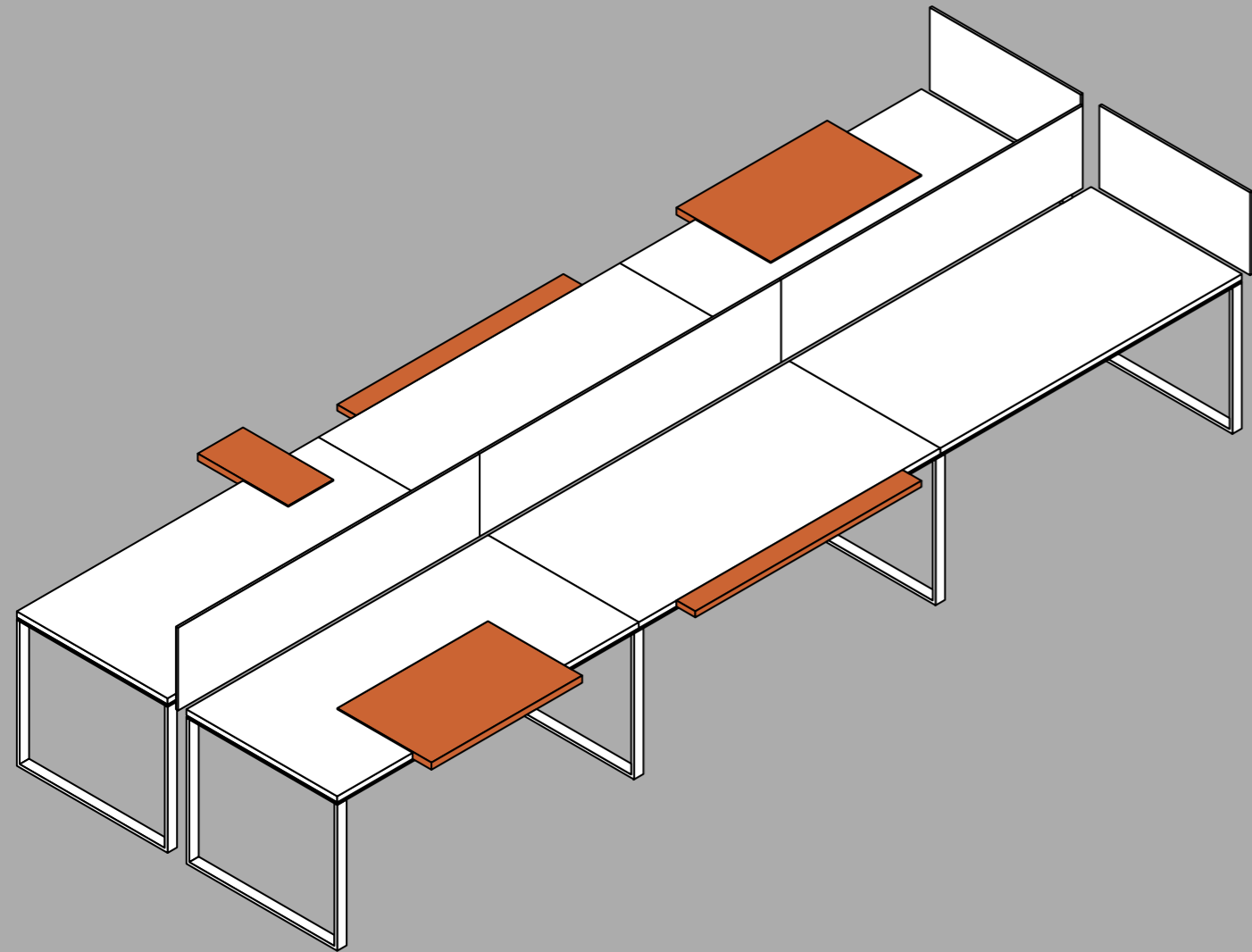

### writing pad

a desk sized mouse pad  
that defines a personal working area.

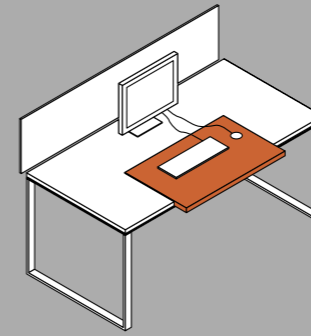

### tech pad

a mouse pad that gives support  
to the hand, wrist and forearm.

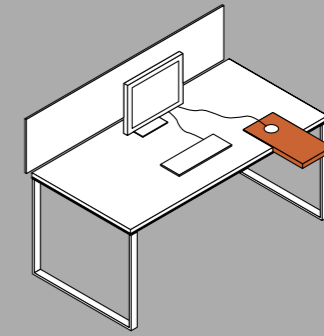

### wrist pad

support for wrists and  
a soft interface to the desk edge.

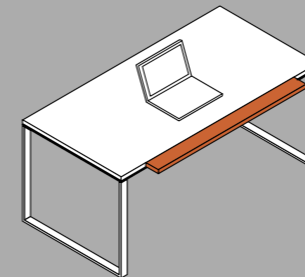

### pen tray

a flexible, light alternative  
to drawer storage.

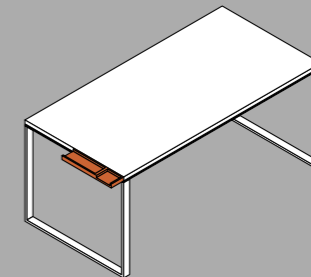

### vertical pad

a pinnable display surface.

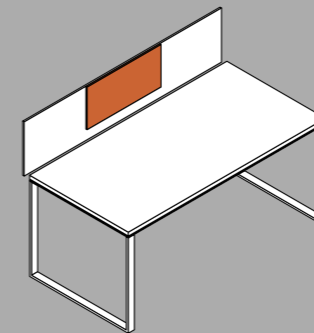

### light panel

light panels define space and also  
support vertical pads and accessory boxes.

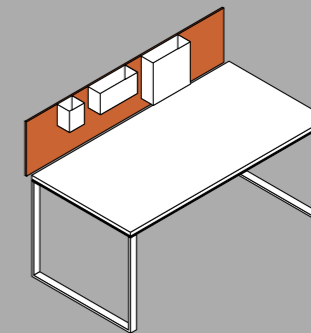







## workstorage

workplace + storage = workstorage.

use storage to create spines,

spacers and communication points.

connect storage to worksurfaces at any point.

there no modular restrictions.

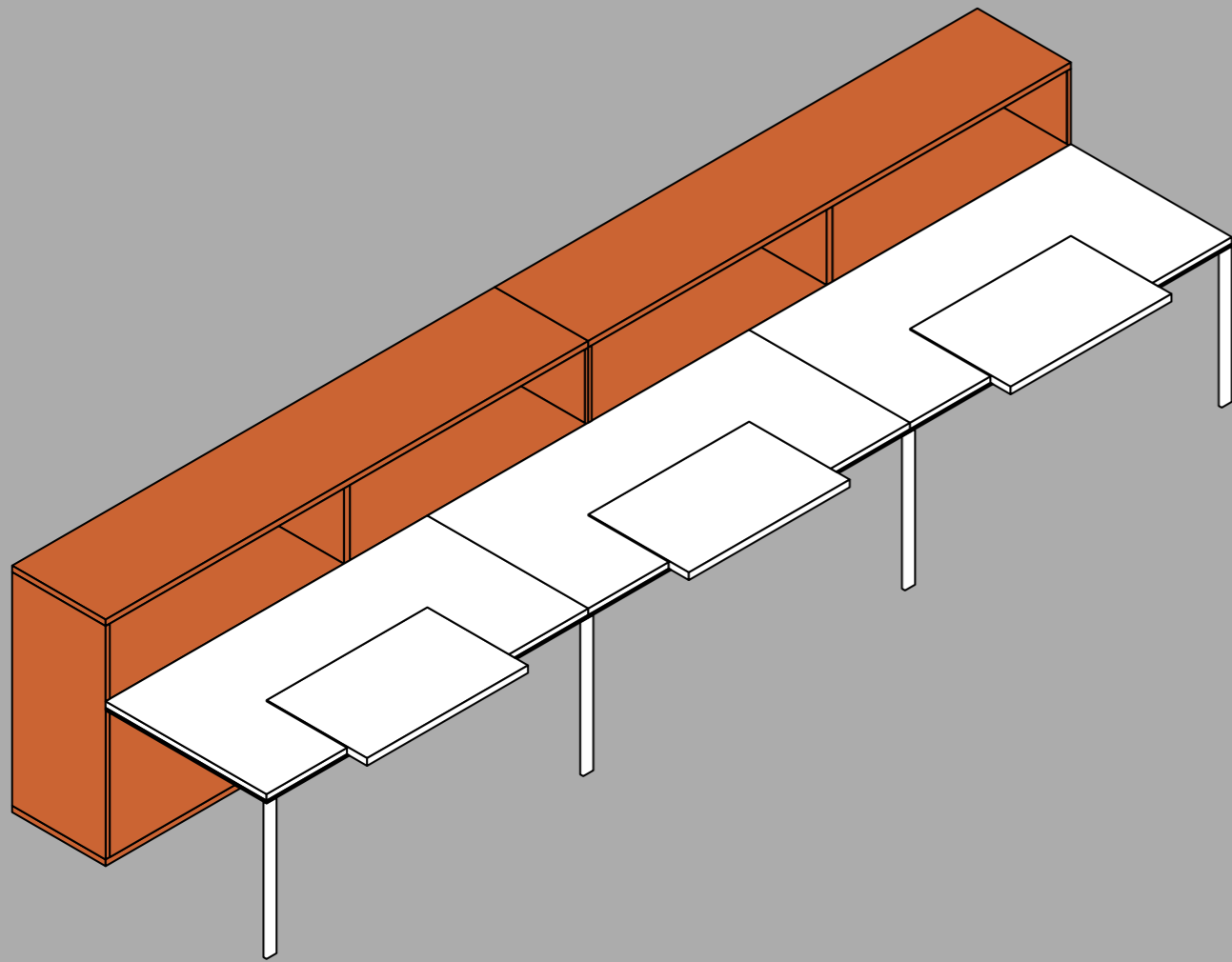

## spines

tables connect to either side.

storage access on either side.

doors and back panels are reversible.

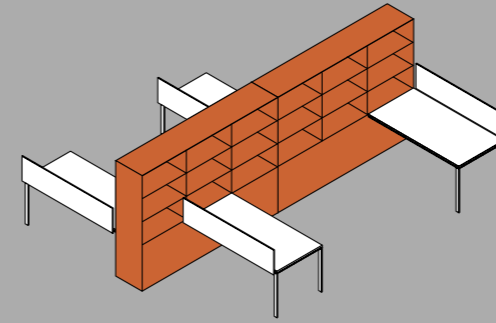

## spacers

define personal space.

separate working groups.

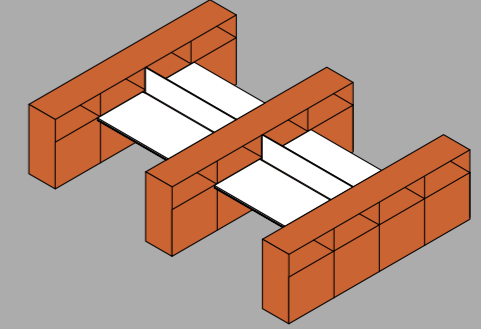

## bridges

worksurfaces suspended between

storage ends. desk top storage access.

corridor storage access.

doors and back panels are reversible.

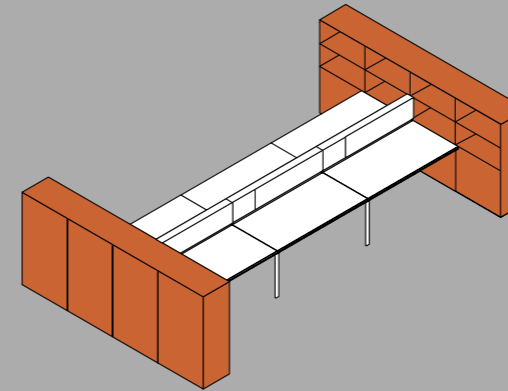

## returns

increase worksurface area.

integrate storage with the workplace.

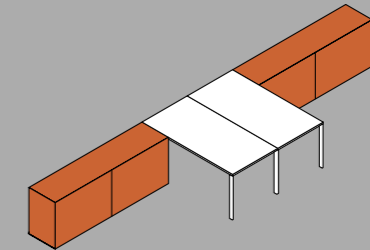

## islands

storage at worksurface or counter height.

points of communication and interaction.

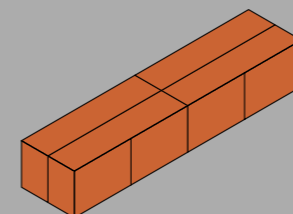

## receptions

above desk storage.

transaction counters.

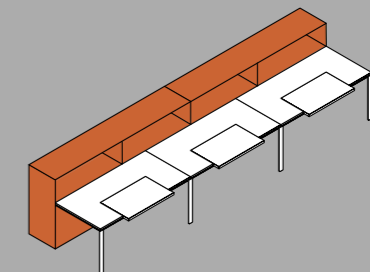







## wa tech

cables made invisible.

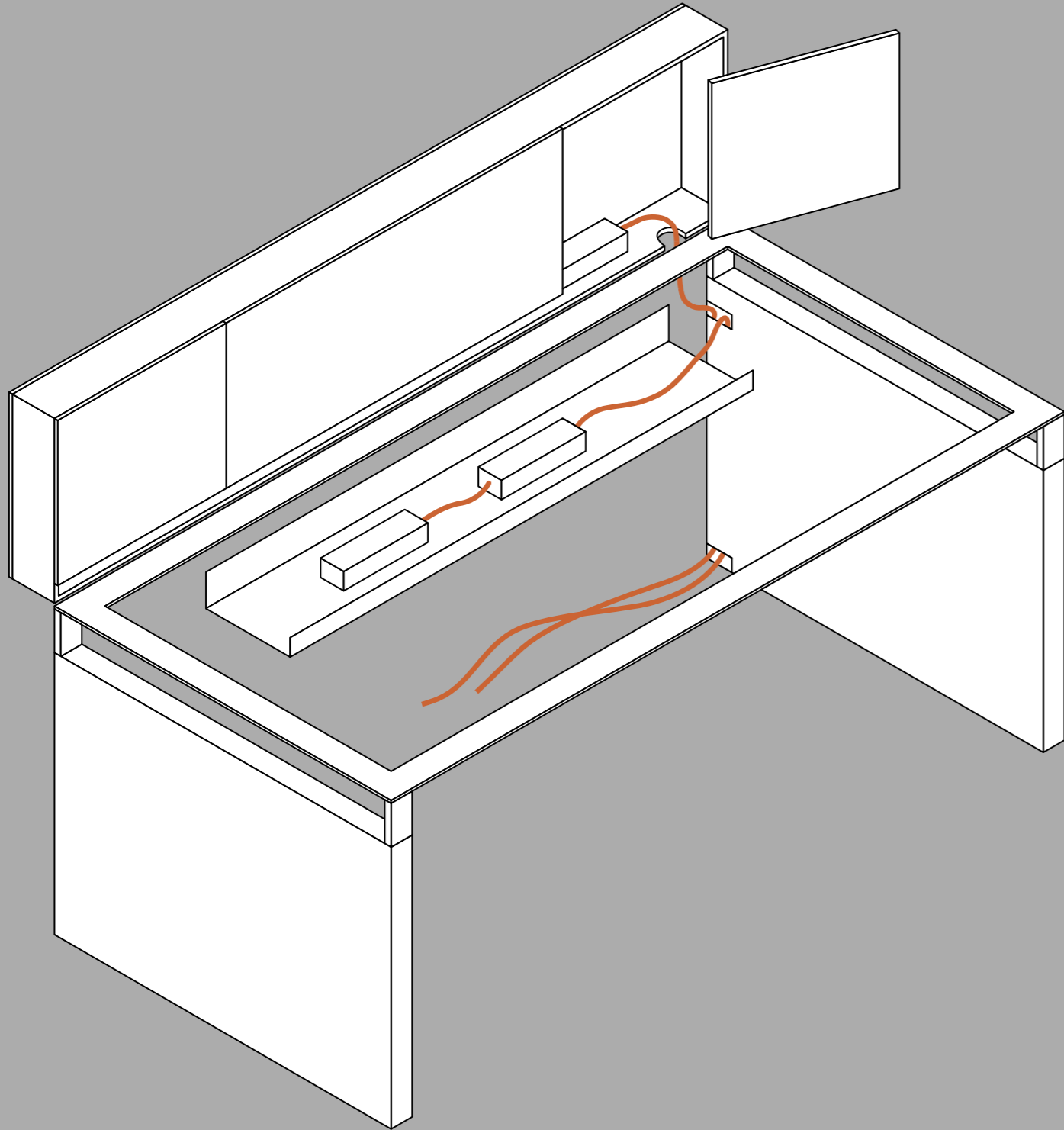

### tech panel

the tech panel gives immediate access to power and data.  
the pivoting door does not intrude into the working area. no visible technology.

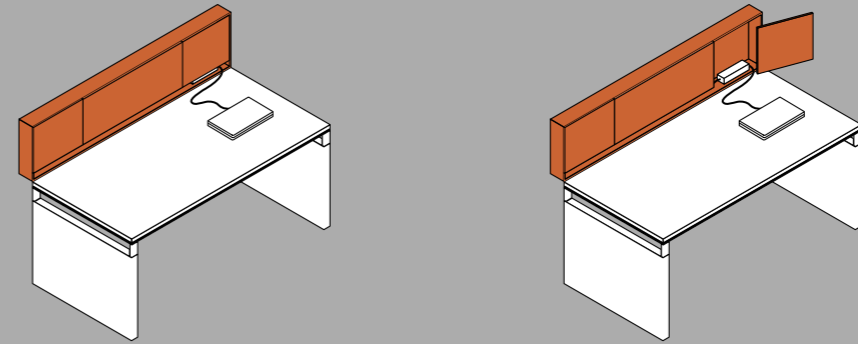

### cable tray

the position is endlessly adjustable, in height, width and depth.  
cable trays are reversible and can also be shared between two desks.  
simply click it into the internal slot.

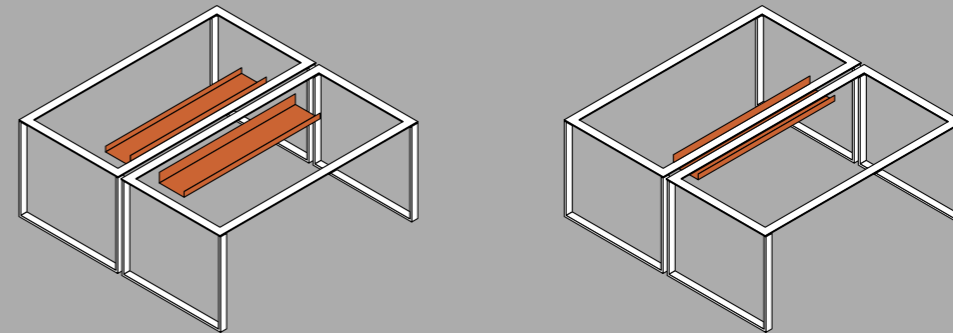

### cpu holder

rotates through 360 degrees. the position is endlessly adjustable,  
in height, width and depth. simply click it into the internal slot.



### cable risers

the panel leg is a vertical conduit with enormous capacity.  
alternative routes are offered by the modesty panel and cable riser.

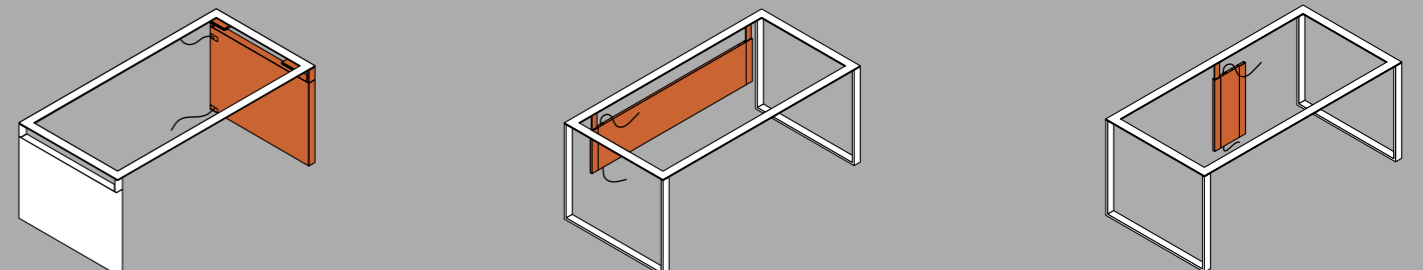











**worksurfaces**

depths: 60, 80cm  
widths: 80, 100, 120, 140, 160, 180cm

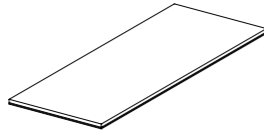

**legs**

panel legs, 'U' legs, single legs

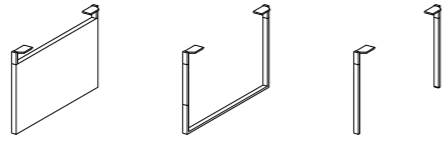

**light panels**

height: 39cm  
widths: 60, 80, 100, 120, 140, 160, 180cm

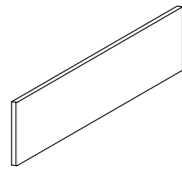

**technical panels**

height: 39cm  
widths: 120, 140, 160, 180cm

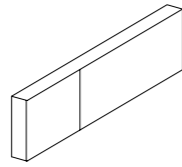

**modesty panels**

height: 30cm  
widths: 90, 110, 130, 150cm

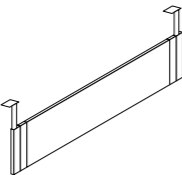

**CPU holders**

11, 18 x 46 x 47cm

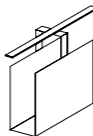

**cable trays**

widths: 90, 110, 130, 150cm

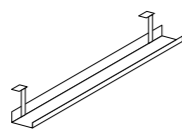

**cable risers**

heights: 30, 50cm  
widths: 25cm

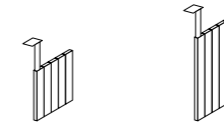

**soft parts**

writing pad, wrist pad, tech pad,  
vertical pad, pen tray

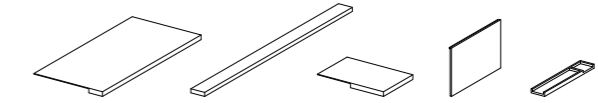

**accessory boxes**

depth: 10cm  
widths: 12, 30cm

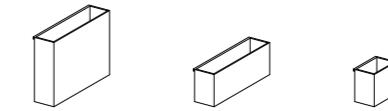

**pedestals**

BF, BBB, BBF shallow and deep

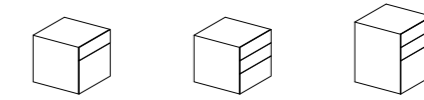

**storage**

heights: 72, 107, 142, 177, 212cm  
widths: 80, 100, 120, 160, 200, 240, 300, 320cm  
door options: hinged, sliding  
shelf options: glass, steel

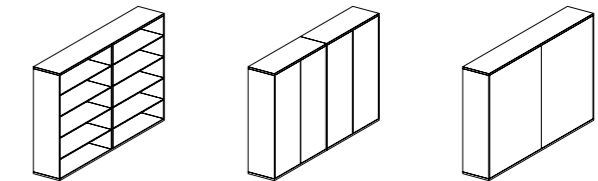

**meeting tables**

heights: 25, 45, 65, 72cm  
widths: 40, 80, 100, 120 cm

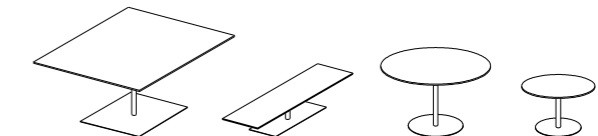

**carbon**

worksurfaces  
legs  
light panels  
technical panels  
free standing screens  
pedestals  
storage  
soft parts  
accessories  
meeting tables

**grey beige**

**light grey**  
worksurfaces  
legs  
light panels  
technical panels  
pedestals  
storage  
soft parts  
accessories  
meeting tables

**off white**

**white**  
worksurfaces  
legs  
light panels  
technical panels  
pedestals  
storage  
meeting tables

**red**

**yellow**  
**blue**  
soft parts  
accessories  
storage doors  
back panels

## locations

Knoll Benelux  
Knoll International SA  
Tour & Taxis  
Av. du Port 86 Havenlaan – C.215  
B-1000 Brussels, Belgium  
tel. +32 (0)2 715 1300  
fax +32 (0) 715 1319  
benelux@knolleurope.com

Knoll France  
Knoll International SA  
268 Boulevard Saint-Germain  
75007 Paris, France  
tel. +33 (0)1 44 18 19 99  
fax +33 (0)1 45 50 20 62  
france@knolleurope.com

Knoll Germany  
91 Goswell Road  
Clerkenwell  
London  
EC1V 7EX  
United Kingdom  
tel. +44 (0)20 7236 6655  
fax +44 (0)20 7248 1744  
germany@knolleurope.com

Knoll Italy  
Knoll International spa  
piazza Bertarelli, 2  
20122 Milano, Italy  
tel. +39 (0)2 7222291  
fax +39 (0)2 72222930  
italy@knolleurope.com

Knoll UK  
Knoll International Ltd  
91 Goswell Road  
Clerkenwell  
London  
EC1V 7EX  
United Kingdom  
tel. +44 (0)20 7236 6655  
fax +44 (0)20 7248 1744  
uk@knolleurope.com

Knoll International  
EMEA and APLA  
91 Goswell Road  
Clerkenwell  
London  
EC1V 7EX  
United Kingdom  
tel +44 (0)20 7236 6655  
fax +44 (0)20 7489 8059  
emea@knolleurope.com

## credits

wa design  
Piero Lissoni and Marc Krusin

design management  
Stéfan Golinski

graphic design  
Ginette Caron, Milan

photography  
Mario Carrieri, Milan

photolitho  
Fotoincisione Varesina, Varese

printing  
Nava Press, Milan

printed in Italy  
October 2011

